

# FORWARD Vs. FLYBACK CONVERTERS: A DETAILED INVESTIGATION FOR PERFORMANCE IMPROVEMENT

**D.SANDEEP KUMAR, Assistant Professor,**  
*Department of EEE,*  
**GURUNANAK TECHNICAL CAMPUS, HYDERABAD.**

**ABSTRACT:** The efficiency, power factor, offset current, and core loss of both forward and flyback converters are investigated in detail in this paper. This research presents a comparison and contrast of the benefits and drawbacks of forward and fly-back layouts. Professionals are able to circumvent converter constraints by visually and aurally confirming performance metrics. The fast switching speeds of metal-oxide semiconductor field-effect transistors (MOSFETs) make them ideal for integrating the two designs. Included in this study is the merging of forward and flyback converter topologies. For optimal efficiency and power factor, use a single-stage balanced forward-flyback converter.

**Keywords:** Forward-flyback; MOSFET

## 1. INTRODUCTION

Power electronic converters are crucial in contemporary electrical and electronic devices due to their ability to process, control, and segregate power. The predominant isolated DC-DC converter configurations are forward and flyback converters due to their versatility, cost-effectiveness, and user-friendliness. This is the optimal method to enhance thermal performance, reduce ripple, and increase efficiency for your high-power application. The transformer of the flyback converter is advantageous for low to medium power applications due to its compact size and substantial energy storage capacity. To maximize the utility of these converters in practical applications, it is essential to understand their composition, capabilities, limitations, and overall structure.

As enterprises endeavor to enhance the reliability, efficiency, and efficacy of their power control systems, a thorough examination of forward and flyback converters is increasingly essential. To optimize the transformer's performance, one might refine its design, switching mechanisms, snubber circuits, control strategies, and component selection. Key performance metrics for evaluating the advantages and disadvantages of each design include power regulation, switching losses, transient responsiveness, electromagnetic interference (EMI), and thermal properties. The objective of the study is to explore these themes in greater depth while also proposing enhancements for optimizing converter layouts in diverse contemporary contexts.

A power converter regulates and directs the flow of electricity. The power converter thereafter transmits the appropriate voltages and currents to the devices receiving them.

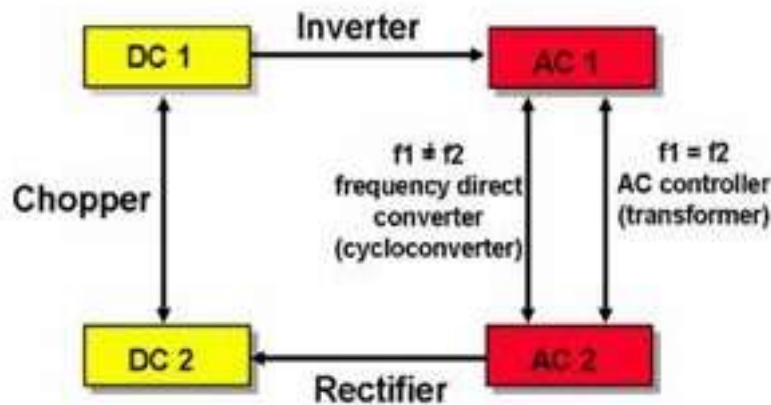

**Figure1:**The categorization of converters

Figure 1 displays a variety of processors. A flyback converter is the optimal choice for minimal output power requirements in an SMPS system. A forward converter separates an unregulated DC input source from a regulated DC input source. It is a standard component of an SMPSS circuit.

## 2. OPERATION PRINCIPLES

Scientists have shown that flyback converters are functionally equivalent to buck-boost converters. One of the components of a buck-boost converter that is shown in Figure 2(a) is a switching MOSFET, while the other is a diode. Two conductors, each created by a single turn, make up an inductor winding, as shown in Figure 2(b). The inductor's principal function is unaffected by the presence of parallel windings because they act similarly to a single, bigger winding. The two windings' connections have been disconnected in Figure 2(c). When transistor Q1 is turned on, only one winding is used. The alternate winding can be used after diode D1 is activated. There is no change to the total current via either winding when compared to the circuit shown in Figure 2(b). On the flip side, the stream makes its way in all sorts of different ways as it flows. There is no change to the magnetic field inside the transformer.

A generator and a magnetic device with two coils are both represented by the same symbol. Be advised that the phrase "two-winding inductor" better characterizes its purpose. This device is also known as a flyback transformer.

Because the current flowing through the flyback transformer's windings is not synchronized, it differs from an ideal transformer. A typical flyback converter's configuration is shown in Figure 2(d). Making a connection between the MOSFET source and the main ground makes the gate drive circuit easier to understand. It is possible to generate a positive output voltage by modifying the phase signals of the transformer. The transformer's efficiency can be enhanced by modifying the turns ratio from 1 to n.

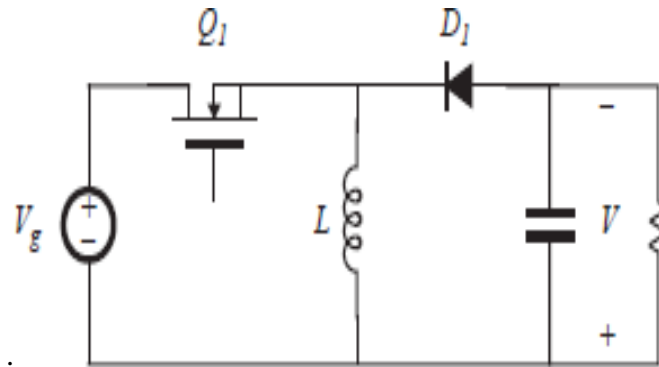

(a) Converting money to make more money

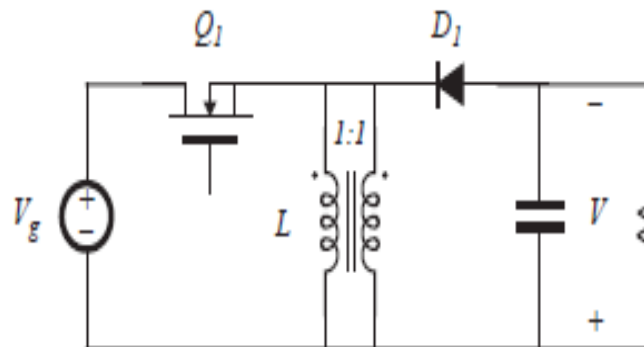

(b) The L-shaped inductor is made by winding two wires in parallel.

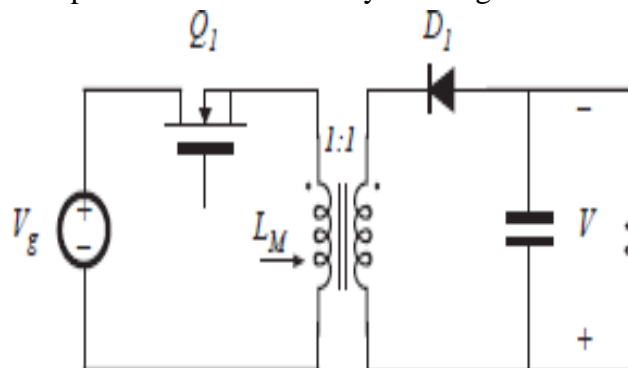

(c) A flyback converter is used because the inductor windings are isolated.

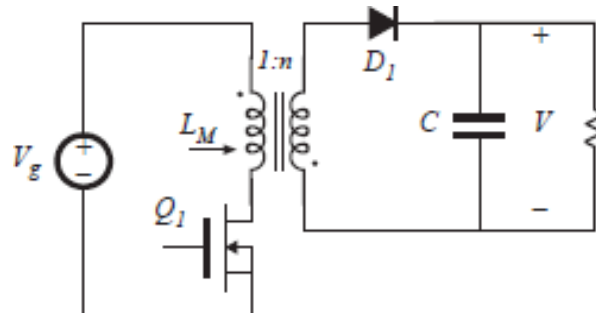

(d) having a positive output and a 1:n input-to-output ratio.

**Figure2:** Variations on the flyback inverter

### ANALYSIS OF FLY BACK CONVERTER

An easy way to model most transformer-isolated converters is to connect an ideal transformer in parallel with the magnetizing inductance. Using inductance to generate a magnetic field requires strict adherence to the known laws of inductance. It is crucial to keep the volt-second

equilibrium stable while the machine is operating in steady-state. This means that the average voltage provided to the transformer's coils must be negative polarity. Use the transformer from the last section's circuit instead of the one in Figure 2 if you can. Presented in Figure 3(a) are the circuit components. Transistor Q1 is responsible for current conduction, and the inductor LM is connected to the direct current source Vg. As seen in Figure 2(a), this is similar to the inductor L in the first buck-boost converter. Diode D1 continues to conduct energy when the inductor's voltage and current change, allowing the stored energy to be delivered to the load.

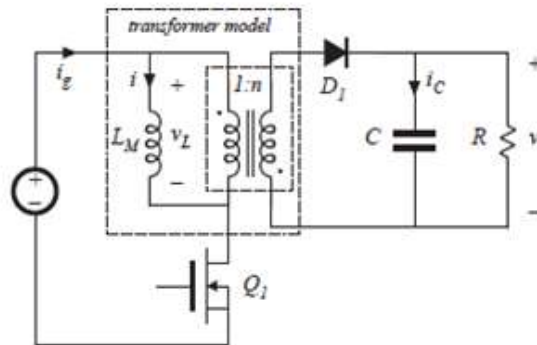

(a) A comparable flyback converter transformer circuit is modeled.

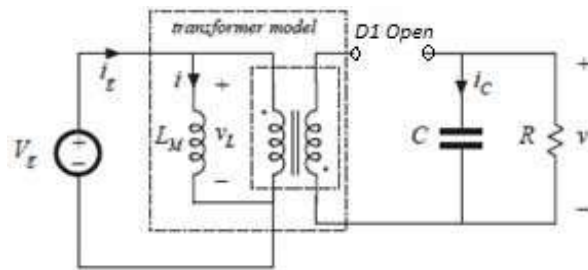

(b) If diode D1 is turned off.

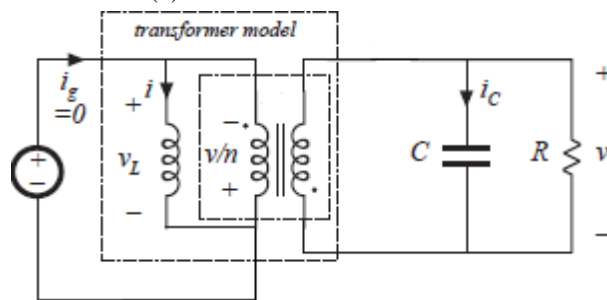

Figure2:

(c) Flyback converter circuits are equivalent to conducting diode D2.

### Concept of forward converter

A common misconception is that the forward converter is an SMPS. The output DC voltage is regulated and isolated even with an unregulated input DC voltage.

Forward converters save energy over flyback circuits. For greater power, 100-200 watt incandescent bulbs are used. Complex fly-back converter output filtering circuitry. Figure 4 displays a simplified forward converter. System contains S-shaped switch with control circuitry and secondary winding rectifying and filtering circuit. Switch S and the transformer's power source-connected primary winding are in series. Modified secondary

transformer load-connected output.

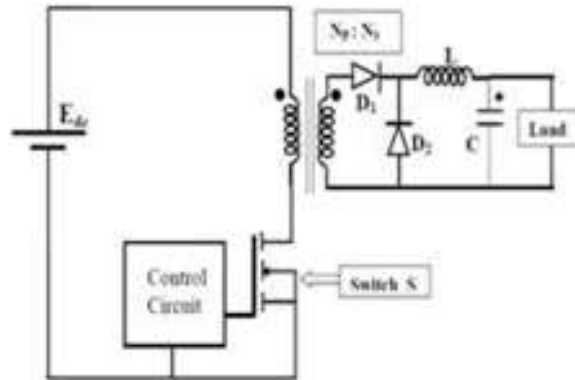

Figure4:The forward converter's essential construction

A perfect transformer would not have any losses, magnetizing current, or leakage flux, according to the specifications. These requirements are for the forward converter's transformer. The circuit's functionality may be fully grasped by investigating its different operating modes, thanks to the careful design of all its components. A secondary winding and a few tweaks to the circuit layout are necessary due to the fact that the magnetizing current in a real transformer is restricted.

#### Analysis of the forward converter

##### Mode-1 circuit operation:

Resetting the circuit to its initial condition is achieved by activating switch S in Figure 4. The main coil receives its power from a direct current (DC) source. When you press the switch, current starts flowing through the main and secondary windings. When a transformer is ideal, the voltages and currents in the main and secondary windings are perfectly matched. Both the main and secondary coils' number of turns dictate this connection. As seen in Figure 5(a), the current's path through the circuit is illustrated. In Mode 1, the circuit shown in Figure 5(b) operates in the same way as in Mode 2. The secondary circuit's diode D1 is forward-biased when switch S is closed. So, the input voltage that has been scaled up goes up.

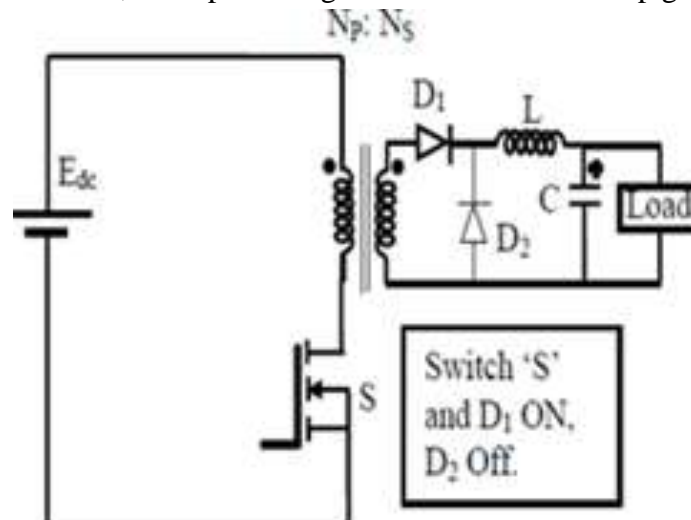

(a) Mode-1's current state.

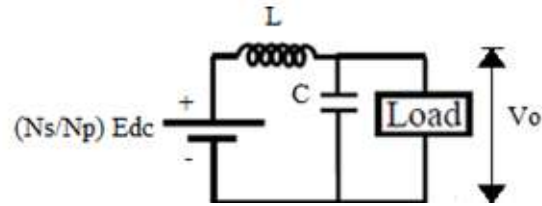

(b) shows the Mode-1 comparable circuit.

Figure5:A forward converter operating in Mode 1.

The secondary circuit's energy reception is proportional to the power input and generator revolutions per minute. In mode-1, a negative bias causes diode D2 to stop working.

**Mode-2circuit operation:**

After that, the option to activate S was disabled. Any time the main and secondary currents are balanced, we say that the transformer is open. On the flip side, the current flowing through the drifting diode D2 is kept constant by means of the secondary side filter inductor. At this time, it is not physically connected to the input or transformer because diode D1 is not present.

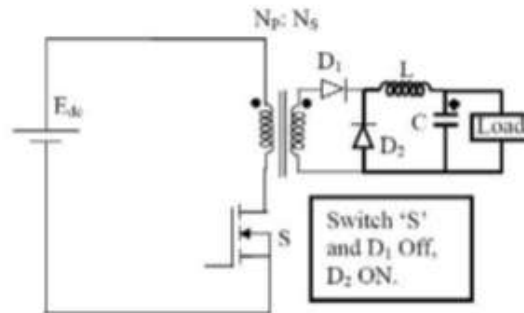

(a) Mode-2 is the current lesson.

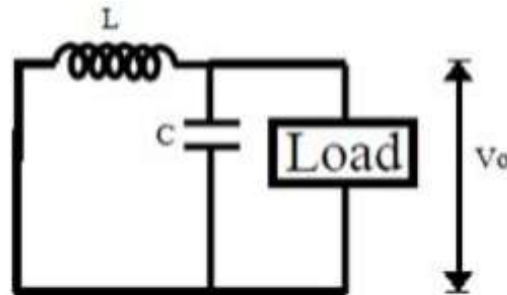

Similar circuits can be found in the second phase.

**Figure6:Mode-2operationofforwardconverter**

The dense line in Figure 6(a) is the circuit's current-flowing portion. Figure 6(b) illustrates a Mode-2 circuit that is comparable. In a similar circuit, diode D2 conducts current from P to N. An inductor with a supply capacitor and output capacitor in parallel has constant current. Mode 2 users gain no generating power. However, a large output capacitor makes load voltage consistency easier. An active inductor and capacitor maintain load current. Mode-2 load drains the filter's capacitor and inductor energy slowly. Insufficient power input causes inefficiency. A tiny inductor current and voltage loss across the capacitor results. Use the S converter-switch to disable floating mode, which keeps the load voltage above the setpoint, and switch to mode-1.

### 3. OBSERVATION AND DISCUSSION

**Table1:**A comparison of forward and flyback converters is shown in the table below.

Characteristics	Conventional fly back converter	Conventional forward converter
Power factor	High	Low
Power conversion efficiency	Low	High
Core losses	Large	Small
Offset current	High	Low

If you look at the table, you can see that the first item is indicated by the starting number. Forward converters have their benefits and drawbacks when compared to flyback converters. It would appear that the problem that each side is responsible for can be solved by the other. One possible solution to the problems we've already spoken about is a smooth changeover from forward to fly-back. Figure 7 shows a high power factor converter that is efficient. This converter can be used as a forward or flyback converter depending on which switch is turned on or off. During the transition time, power cannot be transmitted, making it tough to achieve a high power factor. The suggested converter operates as a forward converter independent of the supplied voltage due to its use of the charge-balanced capacitor  $C_b$ . Core losses may occur, the transformer's size may decrease, and the magnetizing inductor's current may fluctuate.

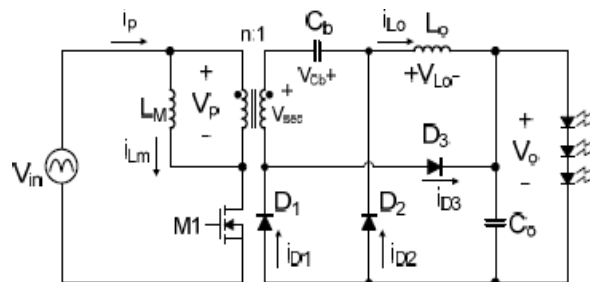

Figure7:The circuit diagram depicts the proposed forward flyback converter.

### 4. ANALYSIS OF THE PROPOSED CONVERTER

Both the flyback and forward converters make use of the offset current that is created by the magnetizing inductor.

$$\langle i_{LM}, flyback \rangle = \frac{I_o}{n(1-D)} \quad (1)$$

$$\langle i_{LM}, forward \rangle = \left(1 + \frac{Nc}{Np}\right) \frac{V_{in}}{2LM} D^2 2Ts \quad (2)$$

The relationship between the flyback converter's load current  $I_o$  and the offset current of the magnetizing inductor is clearly seen by equations (1) and (2). In a forward converter, the shift current is unaffected by  $I_o$ . Due to the close relationship between the flyback converter's offset current and load current, core loss could increase if a larger transformer was used. There are a number of ways in which the forward converter excels above the flyback converter. These include transformer size and efficiency.

#### Voltage Conversion Ratio

By using the volt-second balance rule on the  $L_M$  and  $L_o$  inductances, we can find the voltage conversion ratio of this converter. Throughout the time intervals from  $t_1$  to  $=DTs$  and from  $t_2$  to  $=(1 - D)Ts$ , the voltages across  $L_M$  are denoted by  $V_{in}$  and  $n(V_o + V_{cb})$ . Because of this,

the following solution is workable.

$$D V_{in} = n (V_o + V_{cb}) \cdot (1 - D) \quad (3)$$

Time spent working (D) and time spent traveling (Ts) are two separate ideas. From time t1 until time =DTS, the voltage across Lo can be expressed as Vin/n + Vcb - Vo. From time t2 to time ts, it can be written as (1 - D) Ts. The next number can also be found in this way.

$$V = \frac{D V_{in}}{n} + D V_{cb} \quad (4)$$

Combining equations (3) and (4) gives the voltage Vcb across the balancing capacitor Cb as

$$V_{cb} = D V_o = \frac{D^2}{n(1-D^2)} V_{in} \quad (5)$$

From equation (3) and (5), the output voltage Vo can be obtained as

$$V = \frac{D V_{in}}{n(1-D^2)} \quad (6)$$

### Voltage stress of switch and diode

Even when M1 isn't being used, VDS is still there. The voltage value is equal to the primary side's voltage difference between Vin and n (Vo + Vcb). It is possible to show that the voltage pressure of M1 is the same as

$$V_{DS, stress} = V_{in} + n(V_o + V_{cb}) \quad (7)$$

It is possible to connect the Vo wire to the D1, D2, and D3 output diodes without more problems. Their voltage stresses can be calculated from the number of Vo.

$$V_{D2, stress} = \frac{V_{in}}{n} + V_c \quad (8)$$

Figure 8 shows the voltage stresses of both conventional flyback converters and better forward-flyback converters, as calculated by the transformer turns ratio. By closing switch M1, the voltage applied to D2 can be seen. The input and output voltages will be assumed to be 42 V and 90264 V RMS, respectively, for the sake of simplicity. The picture shows that when the voltage stress on the switch increases, the diode's voltage stress reduces. Switching voltage stress is marginally higher in the suggested converter than in a standard converter due to Vcb's balancing function. Think about how much power will be applied to the switch before choosing the transformer's turn ratio.

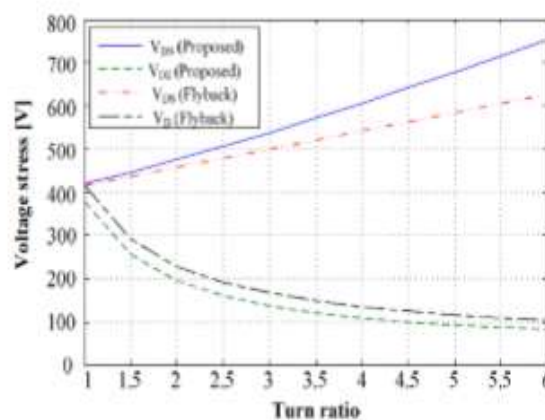

Figure 8: The voltage stresses in forward-flyback and standard flyback converters are compared.

Power supply for 50-100 W electronics, such as TVs and computer displays, sometimes include flyback converters. The ease of installation is one of its many benefits. It is possible

to do a great deal with relatively few parts and inputs.

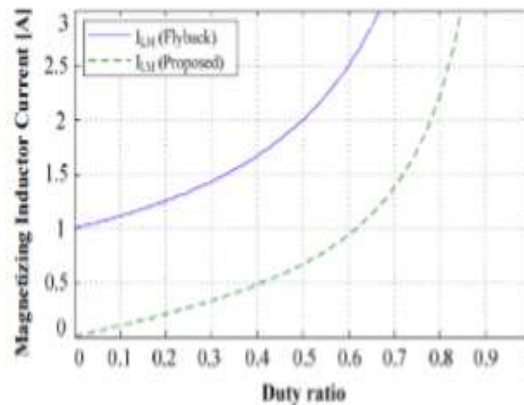

Figure 9: The magnetizing offset currents of a typical flyback converter are determined by the duty ratio.

### Offset current of magnetizing inductor

The current's magnetizing inductor affects the core's size and the amount of energy dissipated within the transformer. It follows that a lower LM offset current is ideal. the average electrical current leaving the generator and its return to its primary side ( $I_{sec}/n$ ) divided by the average electrical current going outward ( $I_p$ ). You can calculate the shift current (ILM) in this way. This proves that LM is the value of the offset current in a conventional flyback converter. An inductor and a magnet are currently coupled.

$$I_{LM} = \frac{i}{n(1-D)} I_o$$

Where,  $I_o$  is the average load current.

The series connection of the balance capacitor  $C_b$  makes it not very sturdy,  $I_{sec}$ . We can say that the offset current is the same as the primary current because  $I_p$  is equal to  $I_{LM}$ . This will cause a  $I_m$  offset current to flow through the planned forward-to-reverse converter.

$$\langle i_{LM} \rangle = \langle i_p \rangle = \frac{D}{n(1-D^2)} I_o \quad (10)$$

Figure 9 describes the effects of forward-flyback and traditional flyback converter duty ratios on the magnetizing offset currents given by Equations 9 and 10. Specifically, the experiment calls for an input voltage of 42 V, an output current of 0.57 A, and an output voltage of 90264 Vrms.

When the balancing capacitor  $C_b$  is included in the proposed converter, as shown in Figure 9, the magnetizing offset current is lower than in the flyback converter. Here, it proves that the suggested converter can improve performance while decreasing core loss.

## 5. CONCLUSION

Following a comprehensive analysis of both the forward and fly-back operations, it becomes clear that the fly-back translator can function autonomously. They have the ability to increase the power factor, but their effect will be smaller than it could be. Improving a forward converter's performance is doable, but doing so will raise the magnetizing offset current. A lot of power is also used by it. The offered version fixes all of these problems. The integrated correcting capacitor  $C_b$  reduces the magnetizing offset current compared to the flyback

converter. The suggested conversion gets rid of wasteful losses in the transformer core, which helps bring it down. We can see that the suggested converter has somewhat more switch voltage stress than the reference converter by looking at the balanced capacitor voltage  $V_{cb}$ . The result is that every adjustment improves performance. This converter uses MOSFETs to combine the ideas of forward and fly-back operation. They stand for the cutting edge of consumer technology. Turning on the switch allows the gadget to potentially translate signals forward. A fly-back transition could be indicated by the switch being in the off position. The power flow is interrupted by the low switching frequency during the switching interval.

## REFERENCES

1. Yoon Choi, Moon-Hwan Keum, Sang Kyoo Han and Jeong-il Kang, High efficiency and high power factor single-stage balanced forward-flyback converter, IEEE, pp.822-827, 2013
2. Bhim Singh, Sanjeev Singh, Ambrish Chandra, and Kamal Al Haddad, Comprehensive study of single phase AC-DC power corrected converter with high
3. Yungtaek Jang and Milan M. Jovanovich, Bridgeless Highpower factor Buck converter, IEEE Trans. Power electron, vol.26, pp. 602-611, Feb 2011
4. Subhra jyoti Modak , Goutam Kumar Panda, Pradip Kumar Saha and Sanskar Das, Design of Novel fly-back converter using PID controller IJAREEIE, Vol. 4 ,pp. 289-297, Jan 2015
5. Abhinav Dogra, Kanchan Pal, Designing and tuning of PI controller for fly back converter , IJETT, vol.13,no.3, Jul 2014
6. Jing Wang, Mixed-signal-Controlled Fly back– transformer based converter with improved Dynamic performance and transient energy recycling, IEEE power electronics, vol. 28, no. 2, Feb 2013
7. Ramon Silva- ortigoza, Victor Manuel Hernandez- guzman, Maryacruz and Daniel, DC/DC Buck Power Converter as a smooth starter for a DC motor based on a Hierarchical Control, IEEE Trans. power electronics, vol. 30, no.2, Feb 2015